

AnS/QnAS/QA1S Base Unit A1S-PLT-D Vibration-proofing Bracket For Mounting To DIN Rail Mounting Guide

BCN-P5648-A

This product is a vibration-proofing bracket to improve resistance to vibration when mounting AnS/QnAS/QA1S base unit to the DIN rail.

1. Component

Part name	Quantity
1) Mounting bracket L	1
2) Mounting bracket R	1
3) Stopper *	2
4) Module mounting screw (M5x20 screw)	4

* Attached to mounting brackets L and R.

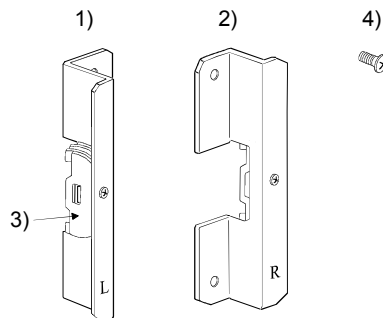

2. Applicable Base Unit and Its Mounting Dimension

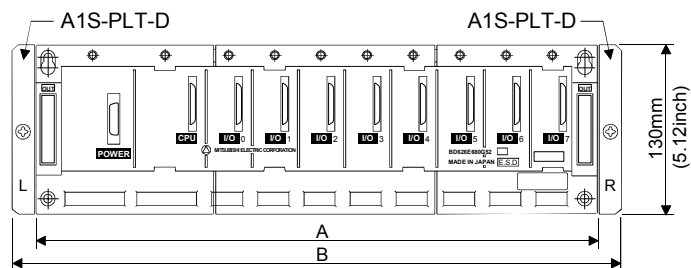

Applicable base unit	A	B
A1S32B	220mm (8.66inch)	245mm (9.65inch)
A1S33B,QA1S33B	255mm (10.04inch)	280mm (11.02inch)
A1S35B,QA1S35B	325mm (12.80inch)	350mm (13.78inch)
A1S38B,A1S38HB,A1S38HBEU,QA1S38B	430mm (16.93inch)	455mm (17.91inch)
A1S52B	155mm (6.10inch)	180mm (7.09inch)
A1S55B	260mm (10.24inch)	285mm (11.22inch)
A1S58B	365mm (14.37inch)	390mm (15.35inch)
A1S65B,QA1S65B	315mm (12.40inch)	340mm (13.39inch)
A1S68B,QA1S68B	420mm (16.54inch)	445mm (17.52inch)
A1SJHCPU	330mm (12.99inch)	355mm (13.98inch)

3. Mounting Procedure

The following shows the procedure for mounting A1S-PLT-D to the base unit.

1) Loosen a locking screw of a mounting bracket.
(Be careful not to let square nut come off.)

2) Setting the mounting bracket in the direction that L (left) / R (right) printing is not upside down, hitch the lower hook to the bottom of the DIN rail. Then, hitch the upper hook of the stopper to the top of the DIN rail. Shift the mounting bracket downward and check that it is securely fixed to the DIN rail.

3) Slide the mounting bracket to the base unit and make them stick together.

4) Fix the base unit and the mounting bracket using the module mounting screw.
(Tightening torque 170 to 230N-cm)

5) Fix the stopper and the mounting bracket using the locking screw of the stopper.
(Tightening torque 102 to 138N-cm)

6) Make sure that the left/right mounting brackets and the left/right stoppers are securely fixed to the base unit and the DIN rail.

Completed

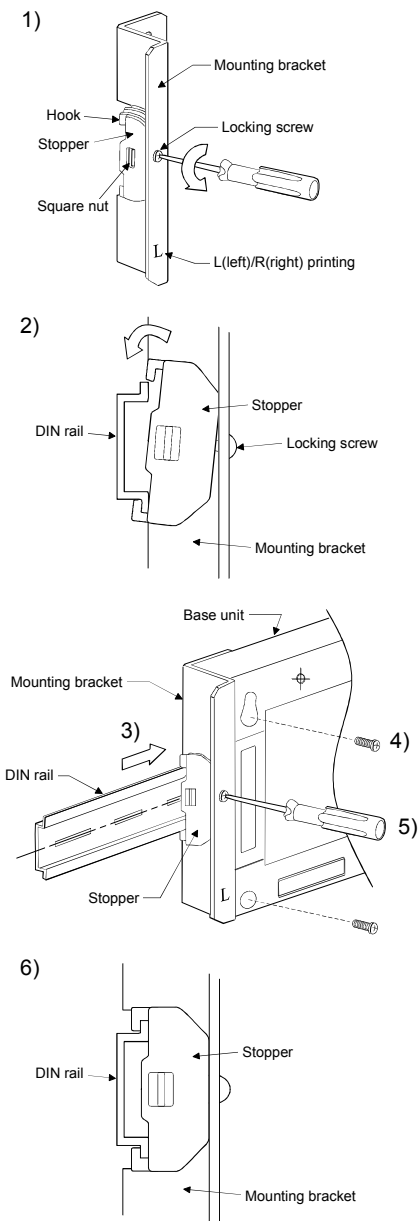

4. Precaution

- To facilitate the mounting operation of A1S-PLT-D, make room (50mm (1.97inch) or more) between the right/left of base unit and the structure/parts.
- For details on mounting the base unit to the DIN rail, refer to User's Manual (Hardware) included with each base unit.